



ZI-9500

www.zicotech.com

RCD tester

Residual **C**urrent **D**evice- circuit breaker

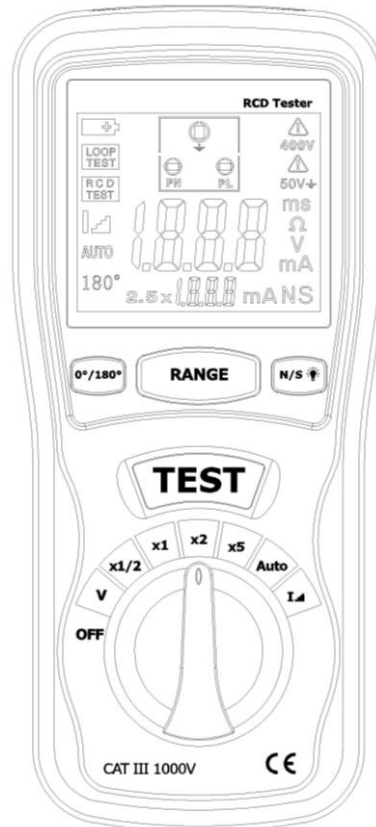

Warnings

Read the documentation and fully assimilate the information it contains before use

Do not use the appliance on voltages greater than 230 V. inspect the appliance before use. Do not use the appliance if it is damaged.

If a 400 V pictogram is displayed, disconnect the appliance immediately and check the installation.

The nature of the test is to trip differential protection mechanisms. At the end of the test, there is therefore no power on the tested port of the installation.

Before using the appliance, you must therefore ensure that the absence of power will not harm any People or damage equipment (medical, computers ,industrial plant, etc.).

The tester is not a No Voltage Tester (nvt).

Use an appliance designed for this purpose.

The manufacturer must carry out the after-sales operations.

Do not attempt to continue the tests if the default voltage (50V) is displayed (calculated for I- Δ n); then check the installation.

Leakage currents in the installation can change the interpretation of the measurements.

This appliance is fitted with Ni-MH batteries. Comply with the national waste disposal instruction.

PARTS & CONTROLS

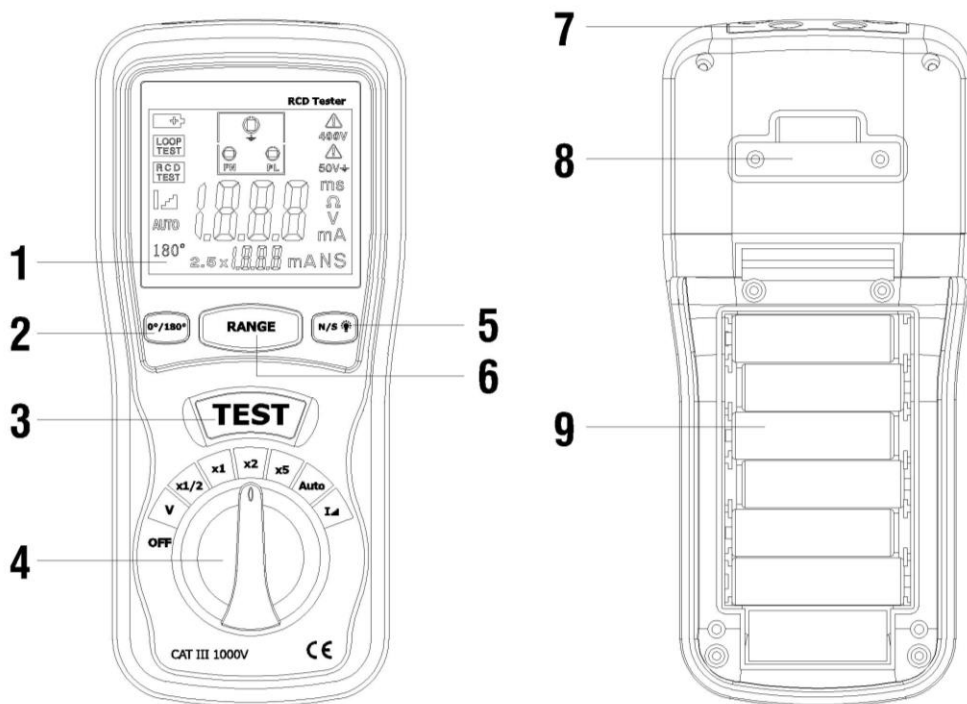

1. Digital Display
2. 0°/180° Button
3. Test Button
4. Rotary Function switch
5. N/S & Backlight button

6. Range button
7. POWER Jack
8. Pothook
9. Battery Cover

Differential tester

The main function of the tester is to test and measure the trip values of RDDS (Residual Differential Devices):

- in trip time (expressed in ms) or
- in trip current value (expressed in mA).

This enables 10mA / 30mA / 100mA/ 300mA / 500mA and 1000mA differential circuit breakers to be tested irrespective of their type (normal or delayed s).

This comprehensive appliance can also be used to test the conformity of the network and the connection of the earthing conductor.

wires state test

Link the test line

Check the wires state:

Before push the "test" button, checks for the following conditions and indicates the test result on the display.

Wiring Condition Display Indication

	N	G	H
Correct Wiring	●	●	●
No Ground	●	○	●
Polarity Reversal	✕	●	✕
Open/Hot Neutral	○	○	○

Legend: ● On ○ Off ✕ Flashing

If the wiring condition is other than normal, the Test is limited on its measurements that can be performed. If a no ground condition exists, only the line voltage measurements are available.

Notes:

- 1) Will not detect two hot wires in a circuit.
- 2) Will not detect a combination of defects.
- 3) Will not detect reversal of grounded and grounding conductors.

Voltage test:

Never apply voltages exceeding 300V to input sockets.

Connect mains lead (13) to the mains connector

Select function V via the function switch

Connect the test leads /mains plug to UUT

Read the measurement result on the display

If the voltage exceeds 300V, In this instance, immediately disconnect the measurement instrument from UUT.

 The tester only used in AC230v +10% -15% (50Hz).

Measuring and testing the differentials

Selection of the differential type and measurement type:

Before testing an RDD, you must select the characteristics on the display (sensitivity, delayed or not) together with the type of test that you are required to perform (trip time or current).

You make the selections by pressing the buttons under each columns. The characteristics are selected one after the other and are outlined by a rectangle

Comment: The selection can be made with the appliance unconnected (switch on the appliance in this case) or connected to the socket (the appliance then switches on automatically).

1 -Selecting the RDD sensibility:

Use the second navigation button to select the appropriate sensitivity $I_{\Delta n}$ (assigned current for differential trip):

10mA / 30mA / 100mA/ 300mA / 500mA or 1000mA

2 –Normal/Delayed selection:

Use the right-hand button to choose the RDD type: N (normal: not delayed) or S* (delayed)* Selectivity rules require that the RDD's fitted at the furthest point on in the installation trip first. S-type RDD's therefore do not exist in 10 mA or 30mA .The tester does not make this choice available.

3 –Selecting 0°or 180°

RDDs can react differently depending whether the default current starts with a positive half-cycle (0°) or a negative half-cycle(180°). The tester automatically sets itself to a current starting with a positive half-cycle (0°).If you want to perform a test that starts with a negative half-cycle, all you have to do is set the appliance to.

4 . Selecting the type of test (x1/2, x1, x2, x5 current,

Auto or Amp :either in current.

The tester shows the "mA" measurement unit
on the screen.

or in time.

The tester shows the "ms" measurement unit
on the screen.

Note: for each new switch on, the selection is positioning in the most common test 10 mA/N/0°.

Measurement results

Once the selections have been made, press the TEST button. The digital result is shown .

Battery Replacement

1. When the low battery symbol"  "appears on the LCD, the six 1.5V 'AA' batteries must be replaced.
2. Remove the screw holding the battery cover
3. Remove the battery compartment cover
4. Replace the batteries observing polarity
5. Affix the rear cover and secure the screw.

Technical characteristics

- 3-digit measurement display
- N or S (delayed) type RDD test, - AC or A (continuous component detection)
- Operates on a TT neutral and TN system
- Operating voltage: 230V (Ph/N) – 10/+6% 50/60 Hz

Measurement specifications	Ranges	resolution	accuracy
Nominal test current	10/30/100/500mA/1A		(-2%+10%)+6Digits
Current selection	0.5 x, 1x, 2x, 5 x nominal current		
Trip time	10-2000 ms at 0.5 x 10-500 ms at 1x 10-150 ms at 2x 10-40 ms at 5x	1ms	±(2%rdg.+2Digits)
Ramp test	0.4 x to 1.4 times nominal rated current		10 %
Mains voltage	230 (+10%/-10%) V	1v	±(2%rdg.+2Digits)

- Cat III 600V
- Double insulation
- IEC 61010-1
- IEC 61557-6 NF EN 61557-6
- IEC 61236 (EMC)
- Locking and warning signals for 400V network voltage and contact potential >50V
- Operating temperature: -15°C /+45°C
- Storage temperature: -25°C /+70°C
- IP40

- Resistance to mechanical shock:1J
- Weight : 700g
- Dimensions: w=92mm l=200mm h=50mm
- Six 1.5V 'AA' batteries

www.zicotech.com